

## Tremec T5

Ratio Available					
1	2	3	4	5	Rev
2.95	1.94	1.34	1.00	.63	2.76

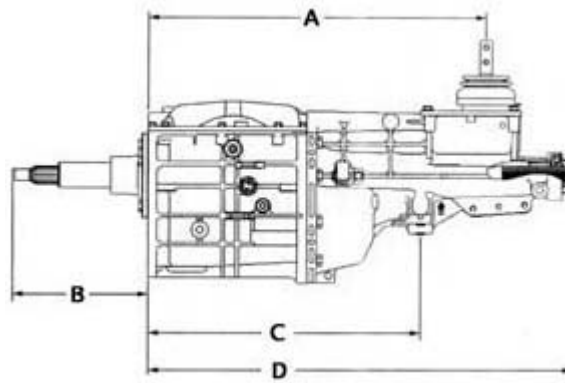

Application	A	B	C	D
1993 & Prior Mustang	19.5	7.2	14.5	24.7

### Features and Benefits:

- Five speed applications	Applicable for a wide range of passenger car and compact utility vehicles
- Aluminum die cast housings	Lightweight, durable construction
- Tapered roller bearings on shafts	Reduced noise and improved durability
- Advanced synchronizer technology: <ul style="list-style-type: none"> <li>* Powered steel formed blocker rings</li> <li>* Organic friction material</li> <li>* Double cone design</li> <li>* Patented strut-type design</li> </ul>	Consistency, high quality Improved durability Lower shift effort Improved durability
- Overdrive synchronizer placed on countershaft	Lower shift effort and reduced noise
- Internal, single rail shift system	Enhanced shift feel, improved durability
- Reverse brake (optional)	Allows immediate shift into reverse w/out clashing

*(All measurements are in inches.)*